

Copenhagen ^{SC7}
Space Copenhagen
2014





Copenhagen^{SC7} Space Copenhagen 2014

Product category

Pendant

Environment

Indoor

Material

Satinized opal glass or metal shade, bronzed brass, black textile cord with wire.

Production process

The shade is spun into shape from a single piece of metal and matt lacquered or made from mouth-blown opal glass. The bracket is made from milled and laser cut bronzed brass or bronzed brass.

Dimensions

Ø: 35cm / 13.8in, H: 40cm / 15.7in

Packaging dimensions

H: 44cm / 17.3in, W: 40.5cm / 15.9in,
D: 40.5cm / 15.9in

Colli quantity

2 pc

Weight

Product: Opal: 3.00 kg / Metal: 2.08 kg
Incl. packaging: 3.13 kg

Voltage

220-240V - 50Hz

Light source & Energy efficiency class

E27 max 150 Watt. The luminaire is compatible with bulbs of energy class: A++ - E. Bulb is not included. Canopy included

Certifications

CE, Class II, IP20

Cord Length

Opal: 400cm / 157.5in
Metal: 300cm / 118.1in

Cleaning instructions

Clean with soft dry cloth. Always switch off electricity supply before cleaning.

→ Stock items

Matt Stone, Matt Plum, Matt Black, Opal

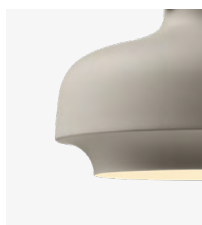

→ Matt Stone

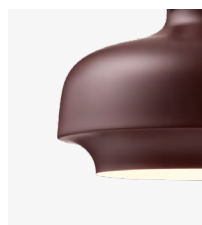

→ Matt Plum

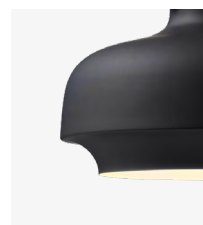

→ Matt Black



→ Opal

Related products

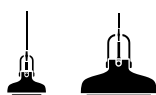

SC6

SC8

&Tradition[®]



COPENHAGEN PENDANT SC7
(OPAL GLASS)

BY SPACE COPENHAGEN
2017



COPENHAGEN PENDANT SC7 (OPAL GLASS)

BY SPACE COPENHAGEN
2017

“Our ambition was to design a pendant with a simple industrial feel, but which was still elegant and poetic.”

The Copenhagen Pendant is an exercise in contrasts. Combining the classic and the modern, the maritime and the industrial, it is a new pendant developed by Space Copenhagen for &tradition. Following the success of their first collaboration, the Fly Lounge Series, &tradition have worked with Space Copenhagen again to produce a pendant range in matt lacquered metal, one of Space Copenhagen’s first lights to enter production.

The Copenhagen Pendant evokes memories of maritime gas lamps silhouetted against a striking nordic sky. With this new addition to the series in matt opal, designers Signe Bindslev Henriksen and Peter Bundgaard Rützou from Space Copenhagen are enhancing the ambient light and the poetic aesthetic appeal.

“We really love the softness of this satinised matt opal glass in combination with the darkened brass,” says Henriksen. **“It enhances the sculptural qualities of the shade in such a beautiful and poetic manner. At the same, the semi-transparent shade allows for ambient light for practically any space or occasion.”**

For Rützou, a key factor for the lamp was their desire to create a soft, cosy atmosphere. **“We live in a part of the world where we have long periods with very little light, so it’s in our bones to seek, create and appreciate warm light that glows.”**

Whether alone or clustered in a group with its siblings in black, white or lacquered pastels, the Copenhagen Pendant makes a modern statement that’s nothing less than stunning. **“It’s a classic icon contemporised,”** adds &tradition Brand Manager Martin Kornbek Hansen. **“It merges the maritime with the industrial in an elegant expression that’s utterly engaging.”**



COPENHAGEN PENDANT SC7 (OPAL GLASS)

BY SPACE COPENHAGEN
2017

Product category	Pendant
Production Process	The shade is made from mouth-blown opal glass. The suspension is made from milled and laser cut bronzed brass.
Environment	Indoor
Material	Satinized opal glass shade, bronzed brass suspension, 4m black textile cord w. wire.
Dimensions (cm/in)	Ø: 35cm/13.8in, H: 40cm/15.7in.
Weight (kg)	3.5kg
Colours	White satinized opal glass and bronzed brass
Light source & energy efficiency	E27 Max 100 Watt. The luminaire is compatible with bulbs of the energy classes: A++ - E. Bulb is not included.
Voltage	220-240V - 50Hz.
Certifications	CE, IP20, Class II
Canopy	Included
Cord length/diameter (cm/in)	400cm/157.5in.
Cleaning Instructions	Clean with soft dry cloth. Always switch off the electricity supply before cleaning.
Package Dimensions (cm/in)	H: 46cm/18.1in, W: 42cm/16.5in, D: 42.0 cm/16.5in.

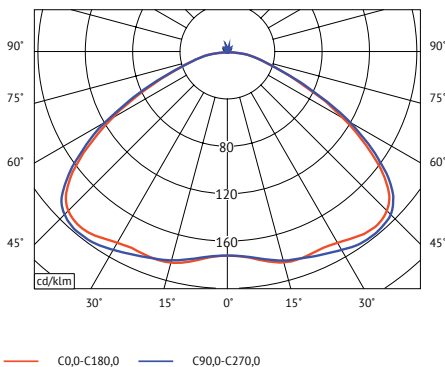
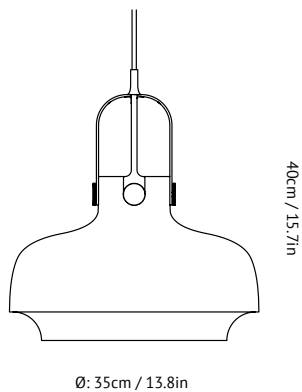

PRODUCT



COLOUR

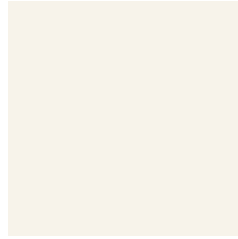

Opal glass



**PRESS RELEASE
COPENHAGEN PENDANT**

2014



&TRADITION

LAUNCHES

COPENHAGEN PENDANT

BY SPACE COPENHAGEN

2014

“Our ambition was to design a pendant with a simple industrial feel, but which was still elegant and poetic.”

The Copenhagen Pendant is an exercise in contrasts. Combining the classic and the modern, the maritime and the industrial, it is a new pendant developed by Space Copenhagen for &tradition. Following the success of their first collaboration, the Fly Lounge Series, &tradition have worked with Space Copenhagen again to produce a pendant range in matt lacquered metal, one of Space Copenhagen's first lights to enter production.

&tradition is a Danish design company established in 2010 with the founding principle being tradition tied to innovation. Our unique library of furniture and lighting spans from the 1930s to the present day and includes designs by internationally renowned designers.

Product category	Pendant
Production Process	The shade is spunn into shape from a single piece of metal and matt lacquered. The suspension is made from milled and laser cut steel which undergoes a special plating process to produce the desired matt finish to compliment the shade.
Environment	Indoor
Materials	Lacquered steel shade with plated steel suspension, 4 meter fabric cord.
Dimensions (cm/in)	SC6: Ø: 20cm/7.8in, H: 25cm/9.8in. SC7: Ø: 35cm/13.8in, H: 40cm/15.7in. SC8: Ø: 60cm/23.6in, H: 53cm/20.7in.
Colours	SC6: Matt blush, Matt moss, Matt slate, Matt black, Matt white. SC7: Matt black, Matt white. SC8: Matt black, Matt white.
Design year	2014
Press info	andtradition.com For image downloads go to andtradition.com / downloads For press releases go to andtradition.com / press For price requests please contact press@andtradition.com
Please contact for more information	PR & Communication manager Camilla Høeg Gade press@andtradition.com T +45 60 20 13 13



SC6, Matt black



SC6, Matt white



SC6, Matt moss



SC6, Matt slate

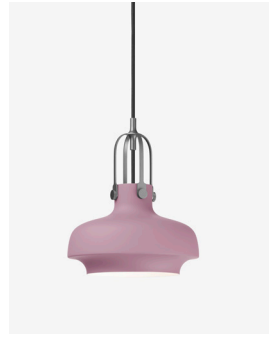

SC6, Matt blush



SC7, Matt black



SC7, Matt white



SC8, Matt black



SC8, Matt white



PRESS RELEASE
COPENHAGEN PENDANT

SC6 & SC7 (MATT OPAL)

2017



&TRADITION

LAUNCHES

COPENHAGEN PENDANT

SC6 & SC7 (MATT OPAL)

BY SPACE COPENHAGEN

THE COPENHAGEN PENDANT EVOKES MEMORIES OF MARITIME GAS LAMPS SILHOUETTED AGAINST A STRIKING NORDIC SKY. WITH THIS NEW ADDITION TO THE SERIES IN MATT OPAL, DESIGNERS SIGNE BINDSLEV HENRIKSEN AND PETER BUNDGAARD RÜTZOU FROM SPACE COPENHAGEN ARE ENHANCING THE AMBIENT LIGHT AND THE POETIC AESTHETIC APPEAL.

2017

Product category	Pendant
Production Process	The shade is made from mouth-blown opal glass. The suspension is made from milled and laser cut bronzed brass.
Environment	Indoor
Materials	Lacquered steel shade with plated steel suspension or satinized opal glass shade with bronzed brass suspension, 4-meter black fabric cord.
Dimensions (cm/in)	SC6: Ø: 20cm/7.8in, H: 25cm/9.8in SC7: Ø: 35cm/13.8in, H: 40cm/15.7in
Colours	Opal glass
Design year	2017
Light source	SC6: G9 Max 40 Watt. The luminaire is compatible with bulbs of the energy classes: B - E. Bulb is not included SC7: E27 Max 100 Watt. The luminaire is compatible with bulbs of the energy classes: A++ - E. Bulb is not included.
Press info	andtradition.com For image downloads go to andtradition.com / downloads For press releases go to andtradition.com / press For price requests please contact press@andtradition.com
Please contact for more information	Press manager Sasha Bakholt press@andtradition.com T: +45 6020 1313

“We really love the softness of this satinised matt opal glass in combination with the darkened brass,” says Henriksen. “It enhances the sculptural qualities of the shade in such a beautiful and poetic manner. At the same, the semi-transparent shade allows for ambient light for practically any space or occasion.”

For Rützou, a key factor for the lamp was their desire to create a soft, cosy atmosphere. “We live in a part of the world where we have long periods with very little light, so it’s in our bones to seek, create and appreciate warm light that glows.”

Whether alone or clustered in a group with its siblings in black, white or lacquered pastels, the Copenhagen Pendant makes a modern statement that’s nothing less than stunning. “It’s a classic icon contemporised,” adds &tradition Brand Manager Martin Kornbek Hansen. “It merges the maritime with the industrial in an elegant expression that’s utterly engaging.”

SPACE Copenhagen is an architecture and design studio founded by Signe Bindeslev Henriksen and Peter Bundgaard Rützou in 2005, famed for creating interiors for high-end hotels, such as 11 Howard in New York and five-star D’Angleterre in Copenhagen, as well as Michelin star Restaurant Noma and a long list of impressive clients with projects involving furniture, design objects and interiors reflecting their love of natural materials and elegant angle on atmosphere.

&tradition is a Danish design company established in 2010 with the founding principle being tradition tied to innovation. Our unique portfolio of furniture and lighting spans from the 1930s to the present day and includes designs by internationally renowned designers.