

- INSTRUCTION MANUAL -

PAO PENDANT

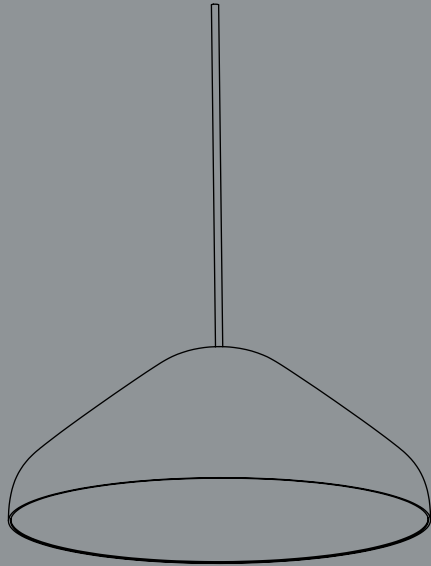

DESIGN BY NAOTO FUKASAWA

HAY

Named after the soft, glowing shape of traditional Mongolian Pao tents illuminated at night-time, Naoto Fukasawa set out to encapsulate the same atmospheric warmth and friendliness in his series of Pao lamps. Using today's advanced LED lighting technology to optimise the efficiency and possibilities of the light source, while ensuring it remains as unobtrusive as possible, in the Pao Pendant Naoto Fukasawa has developed a way of concealing the mechanism inside the shade, whilst still enabling it to emit a warm, homely glow.

By keeping the aesthetics modest and simple, he brings the design in harmony with its environment, reinforcing his primary intention of making the atmosphere pleasant and comfortable. The pendant's shades are available in opal glass or coloured steel with a high gloss finish in different sizes. Their functionality and iconic design make them suitable for a wide range of spaces and uses in domestic and corporate environments.

TECHNICAL DATA

We recommend the following bulb specifications for your Pao pendant lamp:

- / Large Ø47cm: two E27, 11-13W, 2800k Warm White (A series)
- / Medium Ø35cm: two E14, 5-8W, 2800k Warm White
- / Small Ø23cm: two G9, 3.5-5W, 2800k Warm White.
- / HAY recommends using this product with LED bulbs, max. 13W (max. 5W for small).
- / HAY will not accept any responsibility for any accidents or injuries that occur due to the use of incorrect bulbs. For dimming, please check which wall mounted dimmers are compatible with your selected LED bulb.

ATTENTION

In some countries, electrical installation must be carried out by authorised electricians/contractors; please check with your local authority for guidance. The product must not be modified in any way. HAY accepts no responsibility for any products that have been modified or tampered with. This lamp is designed for indoor use only.

- / The Pao pendant is designed to be used with LED based light sources only.
- / Halogen or incandescent light sources should never be used, as they may cause damage to the lamp.
- / HAY accepts no responsibility for any damage due to the use of incorrect light sources.

CARE AND MAINTENANCE

The product can be cleaned with a soft damp cloth and mild detergent. Do not use alcohol or any other solvents to clean the product. The external flexible cable or cord of this luminaire cannot be replaced; if the cord is damaged, the luminaire should be destroyed. Ensure that the power supply has been turned OFF before cleaning the product.



- PARTS -

Ceiling canopy



Shade

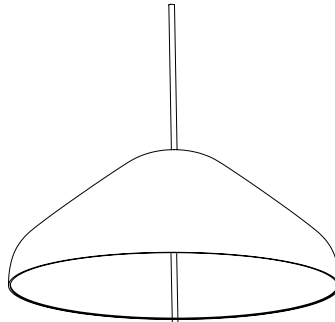

Steel bracket

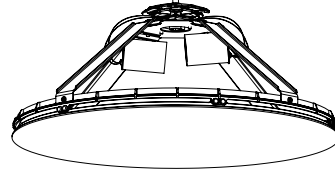

Diffuser



LED bulbs
(sold separately)



E27



E14



G9

1.

Pull the ceiling cap away from the internal magnetic bracket. Loosen the transparent cover and cable grip with a screwdriver and gently remove the cable, pulling it through the cord grip carefully. Remember to also loosen the terminal block connections if the connecting wires are fixed in place there, before pulling the cable through the cord grip.

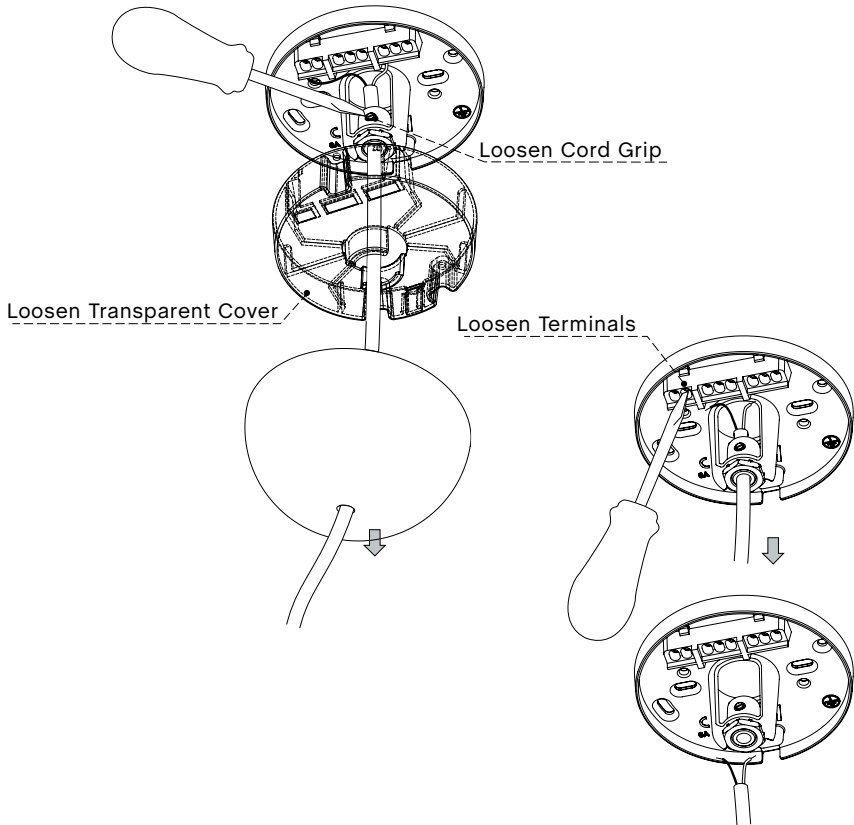

2.

Use a pencil to mark fixing holes either side of the cable exit hole in the ceiling.

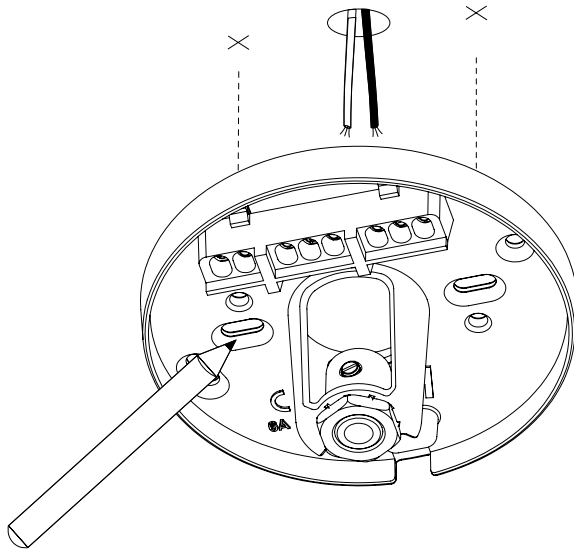

3.

Drill holes and insert wall plugs. Ensure you use the correct type of drill and wall plug for the material you are drilling into.

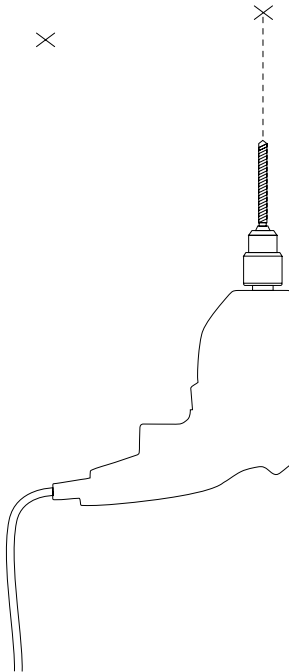

4.

Trim the cable to the desired length, leaving 35 mm of basic single insulation exposed for wiring.

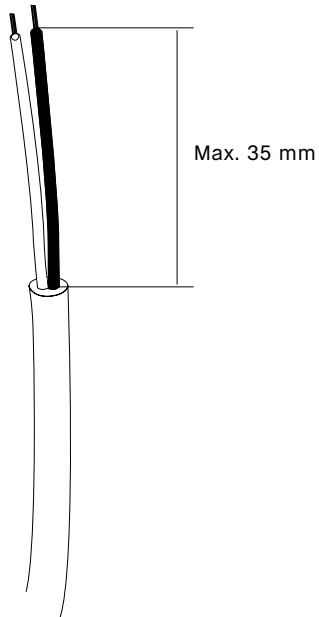

5.

There is a 5 mm wire strip guide provided on the internal transparent cover, as shown below. Strip 5 mm of exposed wire carefully, ensuring both layers of insulation are intact and not damaged.

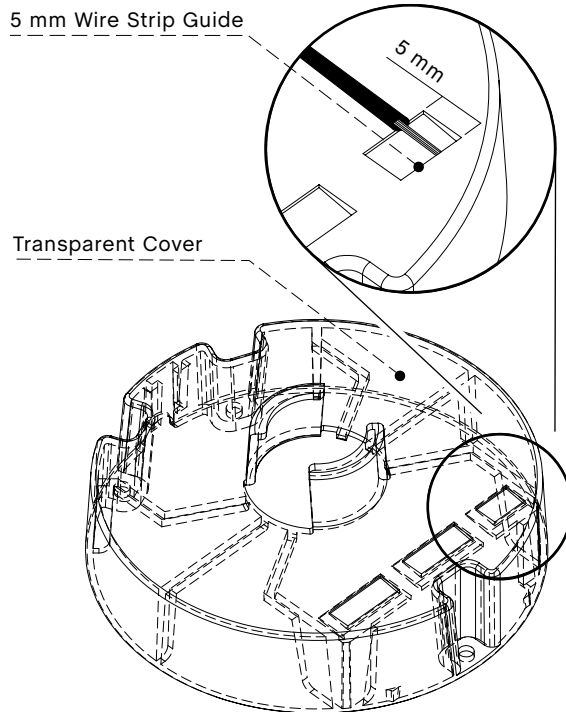

6.

It is advised that any wire exposed with just a single basic layer of insulation is covered with the protective heat shrink provided. (Two sleeves for the basic insulated wire and one sleeve for covering the opening of the pendant cable).



7.

A heat gun can be used to shrink and fix this protective insulation in place, as shown below.

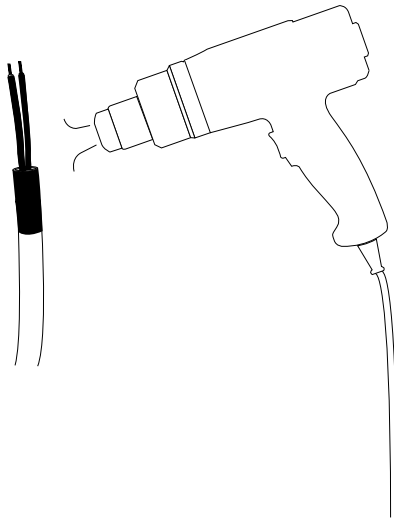

8.

Replace the pendant's cable at the desired length, fix the cord grip sleeve in place and tighten the cord grip, as shown on the clear ceiling bracket. Ensure there is a distance of at least 3 mm between the opening of the pendant cable and the opening of the sleeve.

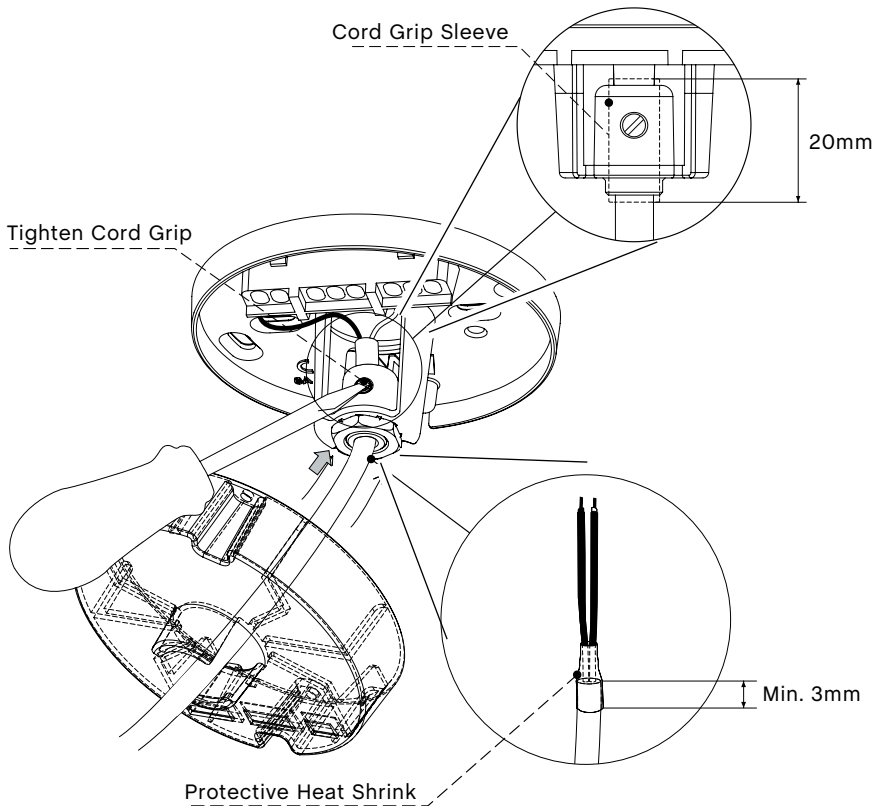

9.

It is advised that any wire exposed with just a single basic layer of insulation is covered with the protective heat shrink provided. (Two sleeves for the basic insulated wire and one sleeve for covering the opening of the source cable).

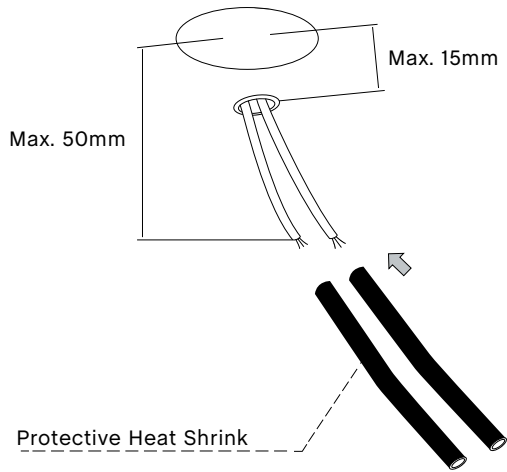

10.

A heat gun can be used to shrink and fix this protective insulation in place, as shown below.

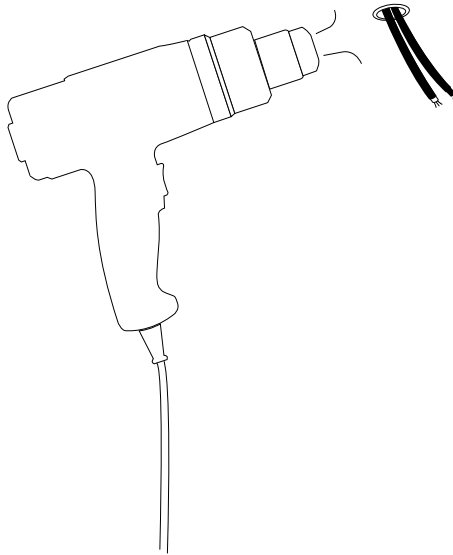

Screw the clear ceiling bracket into the ceiling, ensuring there is enough cable exposed to connect both positive and neutral connections into the terminal block. Use the integrated terminal block on the clear ceiling bracket to connect the live and neutral wires. Both Live (L) and Neutral (N) are clearly marked on the clear ceiling bracket. The Ground (E) connection is only to be used for connecting the source ground connection, and is separate from the integrated terminal block, as shown below.

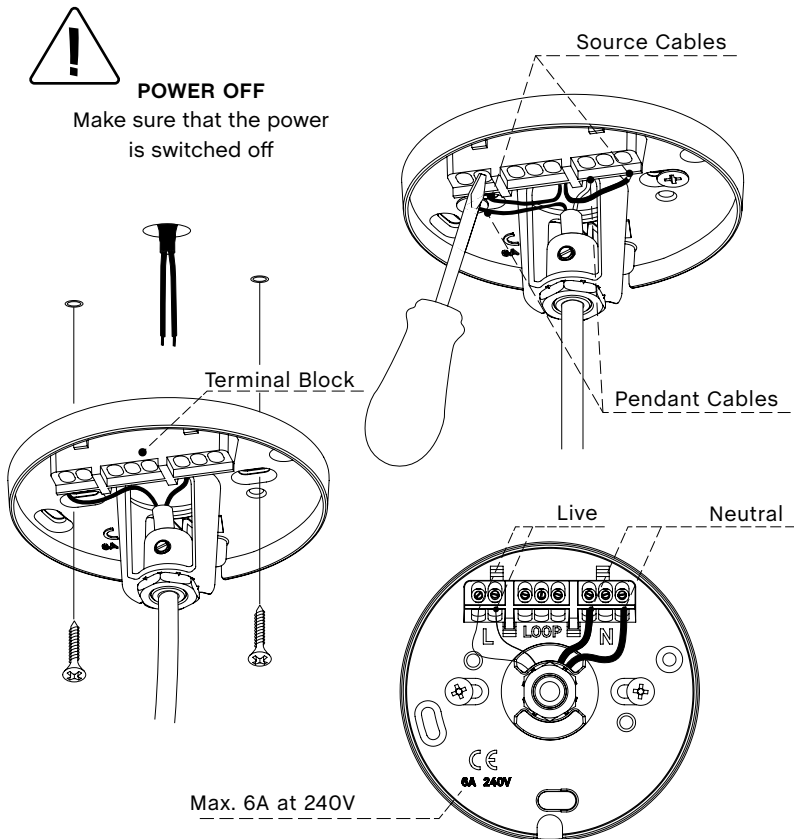

The terminal blocks of the clear ceiling bracket are integrated into a junction box with a loop-in feature. This can be utilised in a number of different ways to optimise the wiring of electrical fittings used in your environment, either for single light fixtures and switches, multiple light fixtures to a single switch or even lamps and ceiling fans connected to a single switch. The below illustration is one example of how this feature can be used to connect multiple light fixtures to a single switch. Max. 3 of the luminaires can be interconnected. (Max. current for looping: 0.2056A). Please note that it is advised that a qualified electrician installs multiple light fittings or ceiling fans that utilise this loop-in feature of our ceiling canopy.

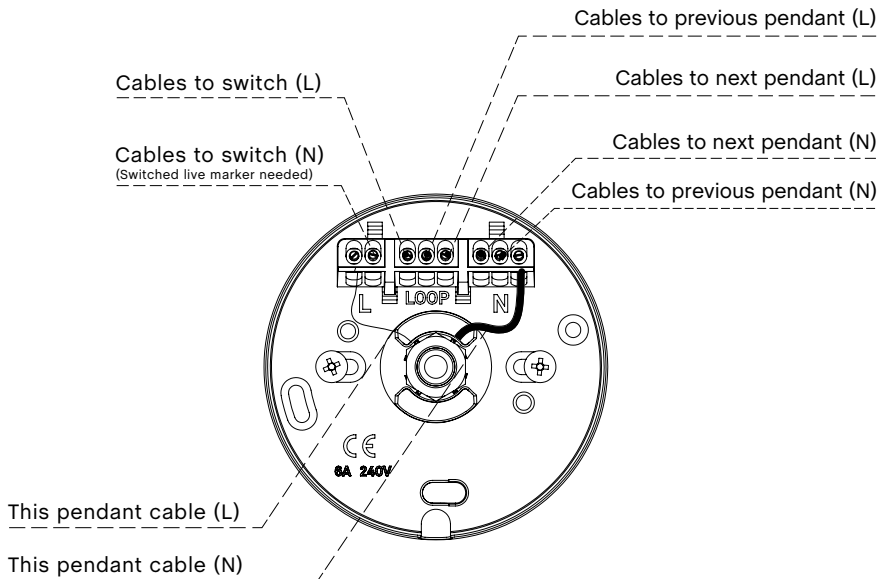

13.

Check to ensure that the protective heat shrink, the cable restraints and cord grip sleeve are still in place after fitting all the wires. Check that all of the Live, Neutral and Ground connections are securely connected before switching the power back on at the mains. Ensure there are no loose cables or exposed bare wires and that the clear ceiling bracket is securely fixed to the ceiling.

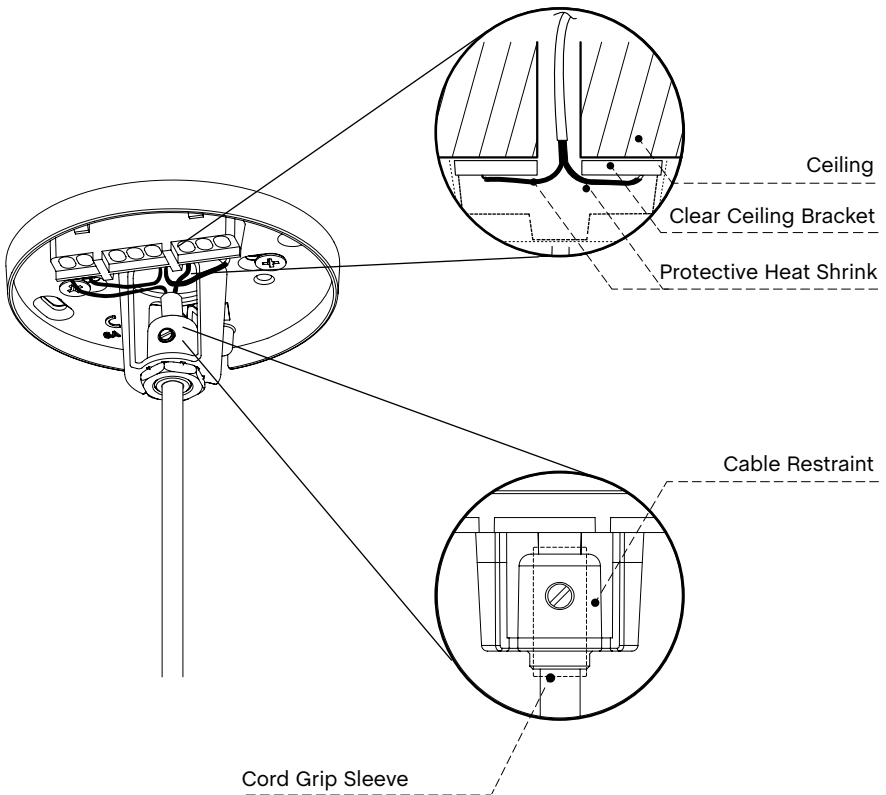

If utilising the mouse hole cable exit, please note the internal cable restraint and integrated cable clamp. The cable clamp tab can be removed and cut to length to suit the cable thickness used, if this is larger than what is already provided. For the source cable, it is advised that any wire exposed with just a single basic layer of insulation is covered with the protective heat shrink provided (Steps 4 - 7). Replace the cable clamp tab, slotting it back into the mouse hole exit. This will clamp the cable tightly when the cover is screwed into place. Please note that the transparent cover may be located in a separate bag in the box.

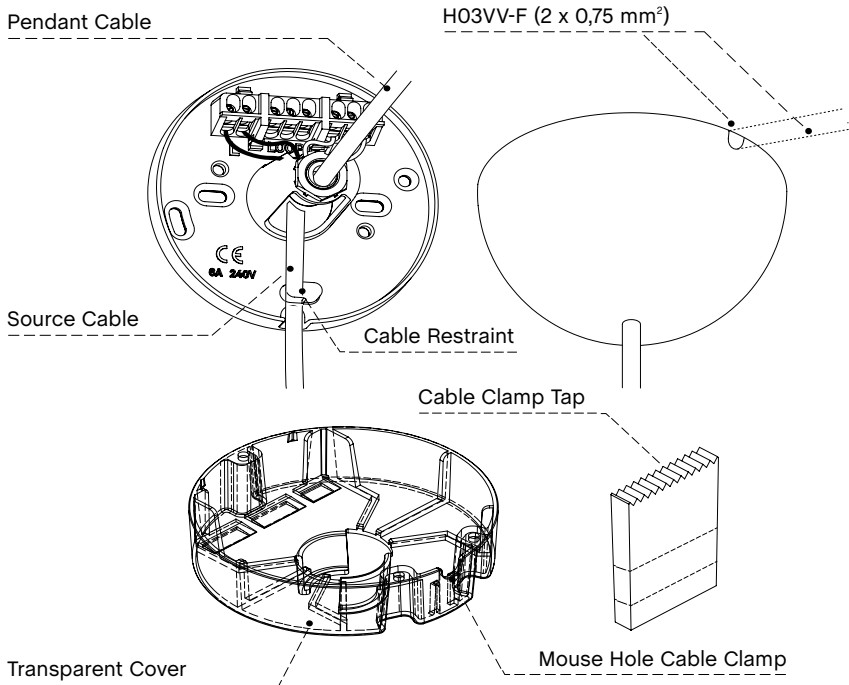

15.

Replace the protective transparent cover over the terminal and clear ceiling bracket, screwing it in place with the three fixings provided. This will isolate the internal electrics during use. Replace the outer magnetic ceiling cap over the assembly, ensuring the mouse hole exits are lined up with the bracket and cap if you intend to utilise this feature.

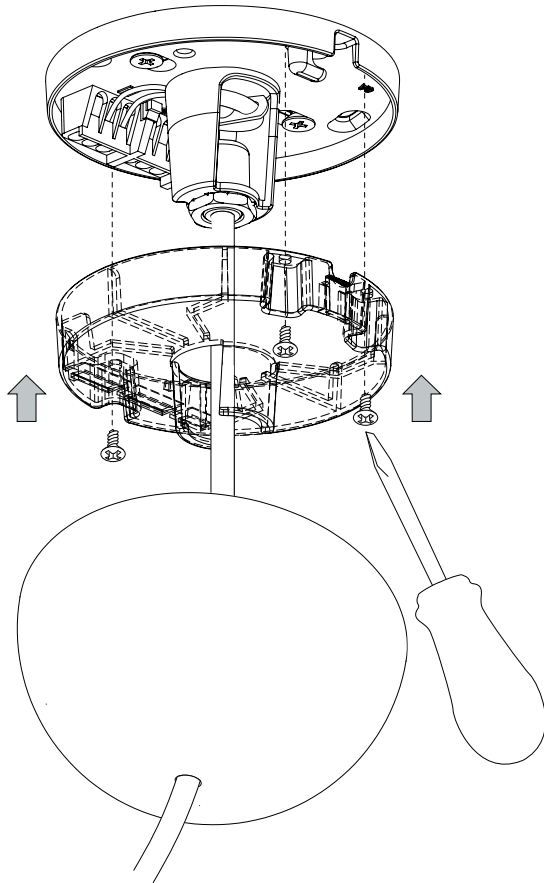

16.

Lift the shade to access the bulb holders.

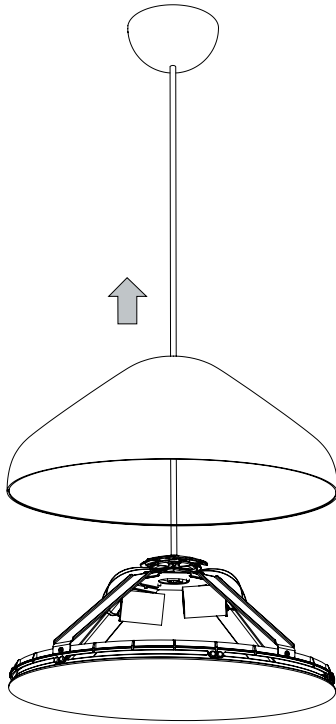

17.

Insert the recommended bulbs into the bulb holders. If possible, we advise two people carry out this task; one holding the shade and one inserting the bulbs.

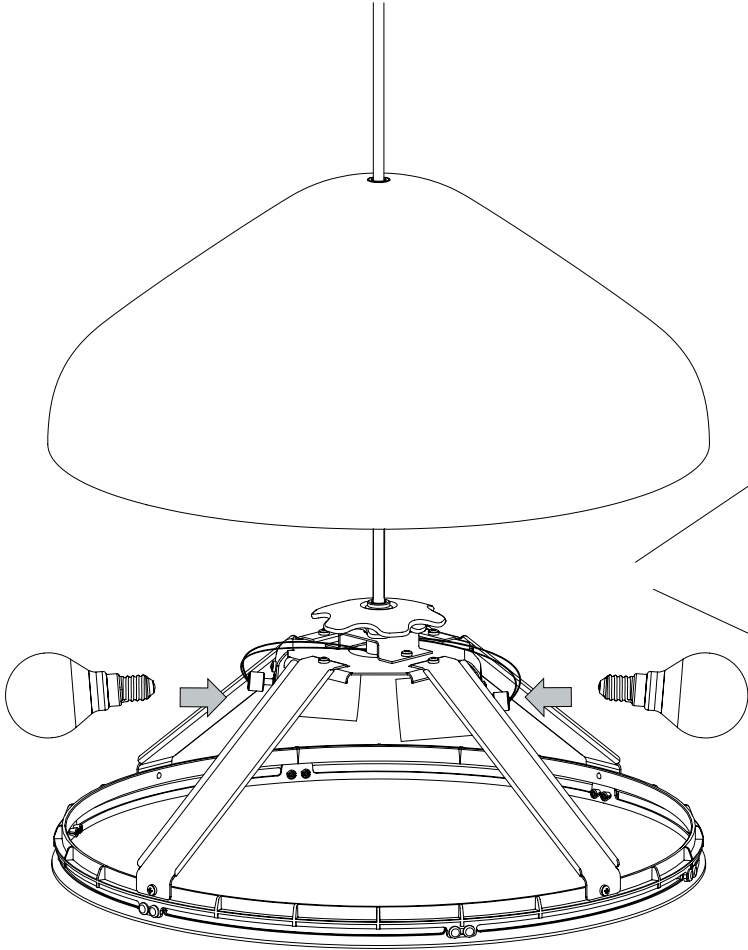

18.

Screw the bulb into the bulb holder, which is located underneath the steel bracket. Repeat on the other bulb holder.



ATTENTION

Do not touch the cables

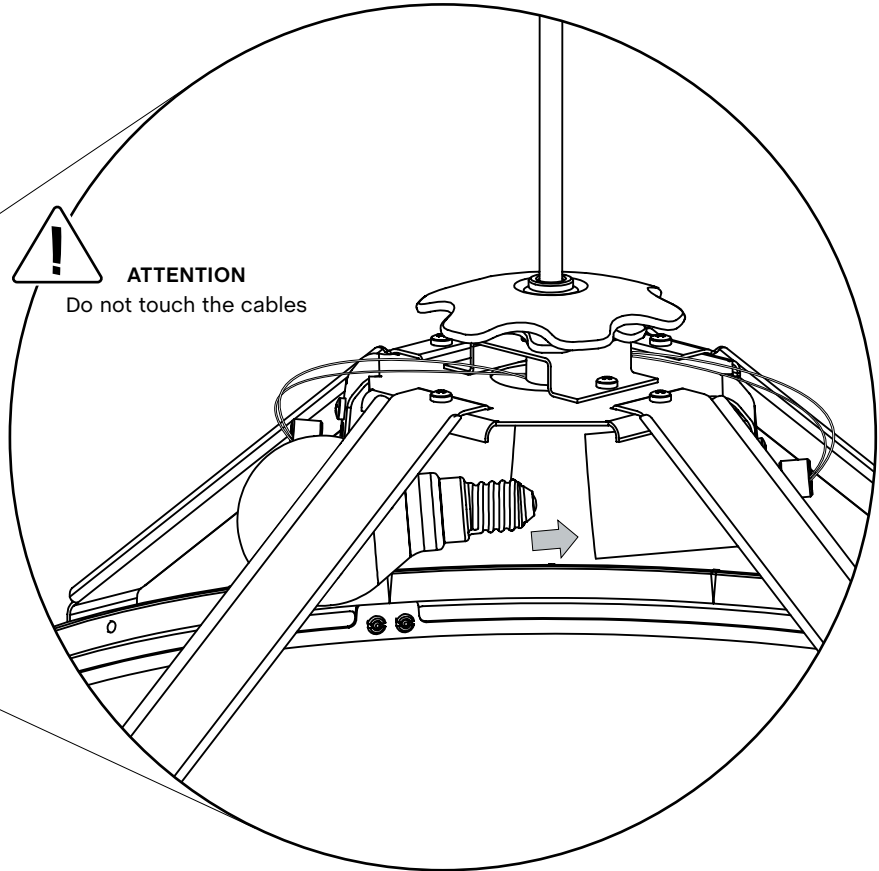

19.

Replace the shade.

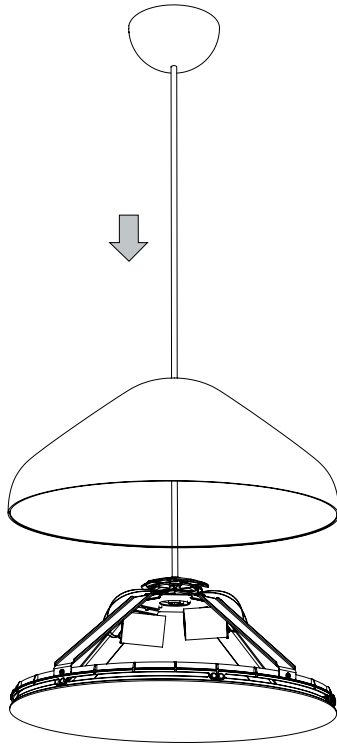

If the diffuser is visible underneath the shade (fig. 1) or the diffuser is too far inside (fig. 2), the shade can be adjusted so that the shade and diffuser are aligned.

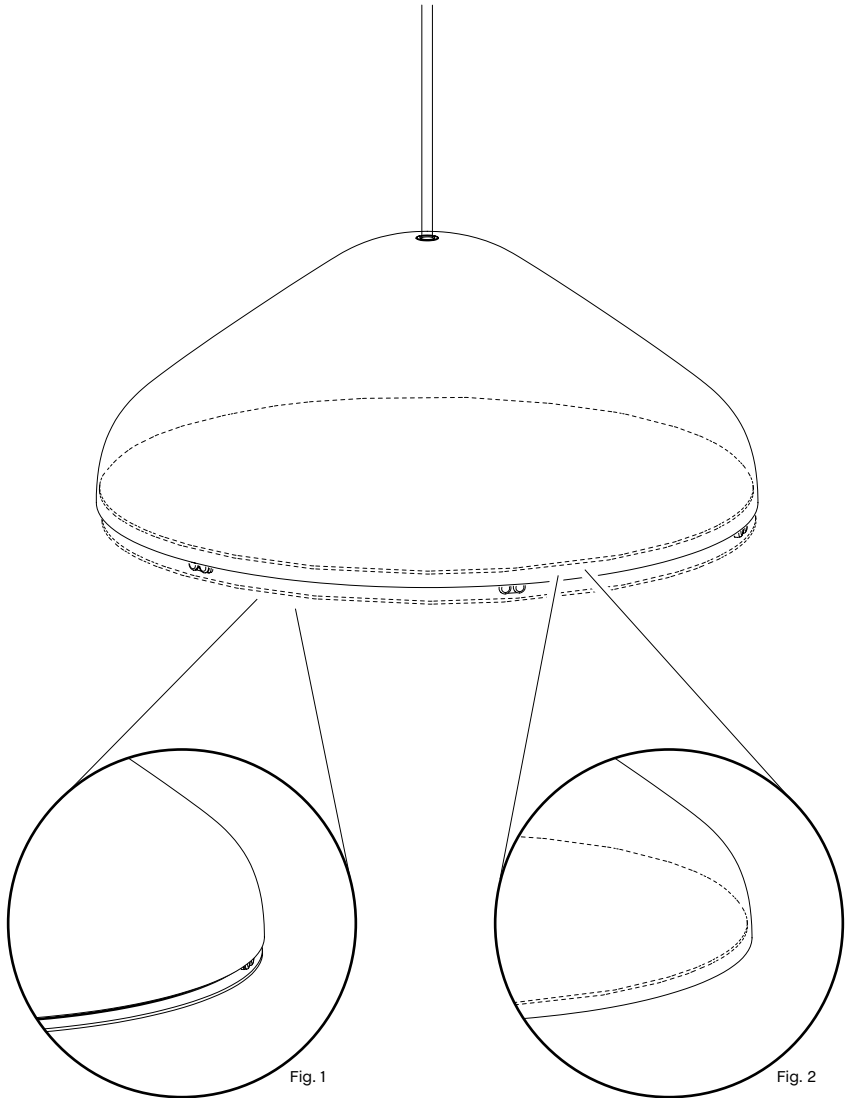
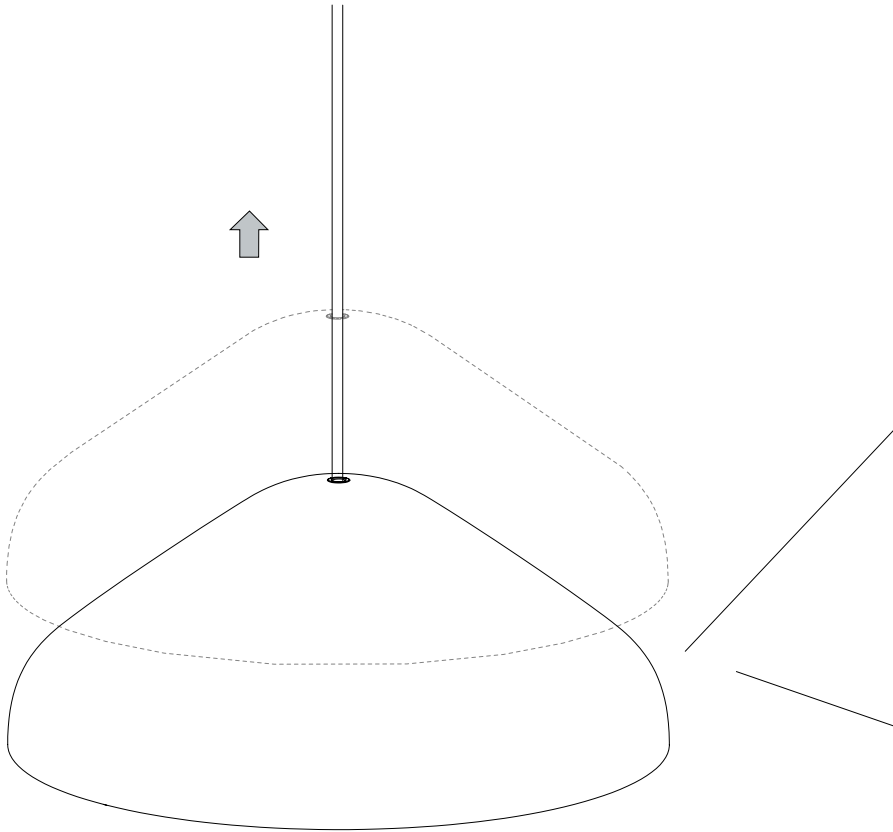

Fig. 1

Fig. 2

21.

To adjust the placement of the diffuser you need to lift the shade. Again, we recommend two people carry out this task; one to hold the shade and the other to adjust.



Adjust the height of the shade by screwing the plastic adjuster until the bottom edge of the shade and the diffuser are aligned. Screw it clockwise to lower the shade and counterclockwise to lift the shade.

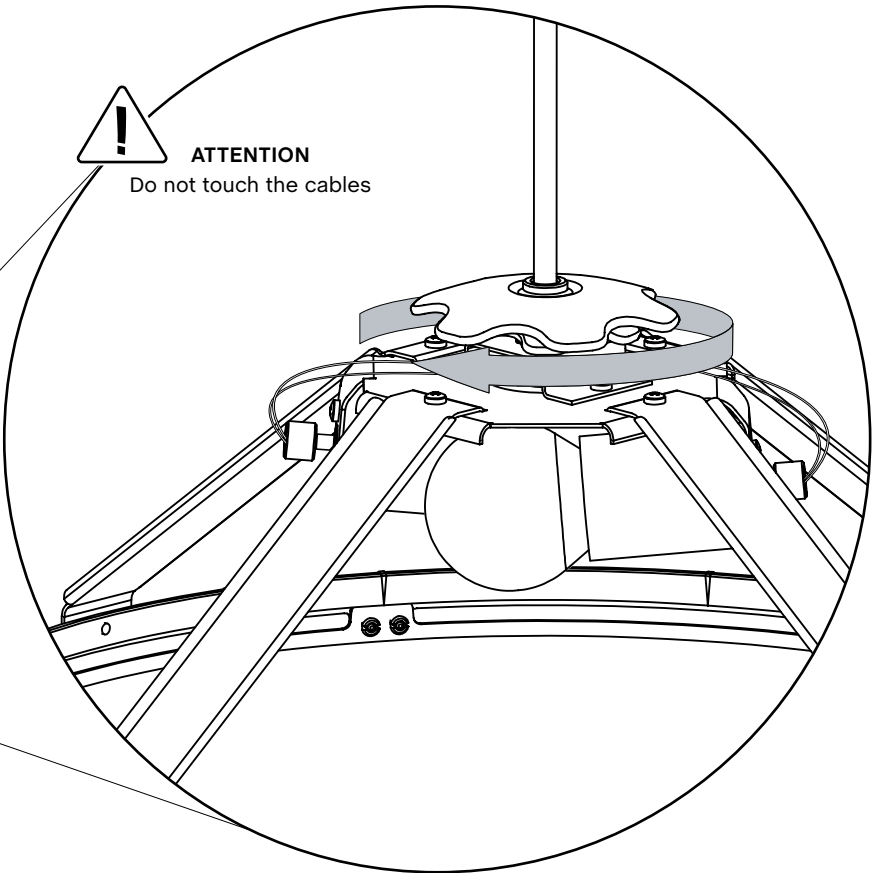

23.

Once all the steps have been carried out, the lamp is ready for use. Please note that there are several alternative configurations for hanging your Pao pendant or pendants other than directly below the supplied ceiling canopy, if the power supply is not conveniently located. Once again, please note that it is recommended that a qualified electrician installs your pendant lamps.

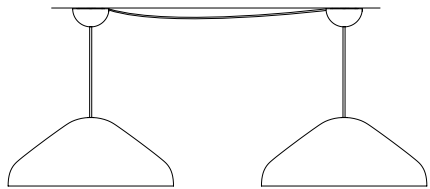
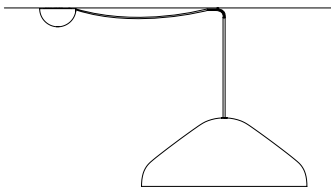
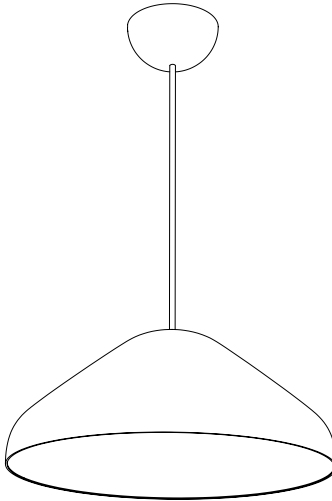

Havnen 1 8700 Horsens Denmark
+45 4282 0282 / hay@hay.com

HAY