

AIR

DESIGN BY
FRANSEN DESIGN STUDIO

Ø22cm + Ø28cm

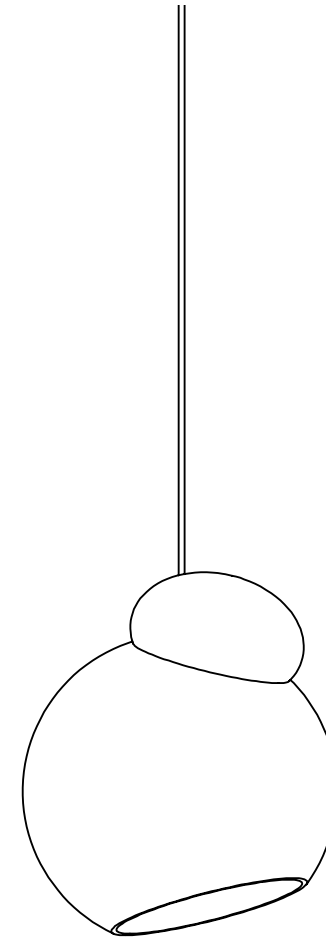

Frandsen has been designing,
producing and marketing lamps
since 1968

*"It is important for us to design
lamps in beautiful materials, and
to make sure that our products
are signalling quality and taste"*

FRANSEN

WWW.FRANSEN.COM

1

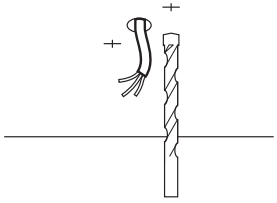

2

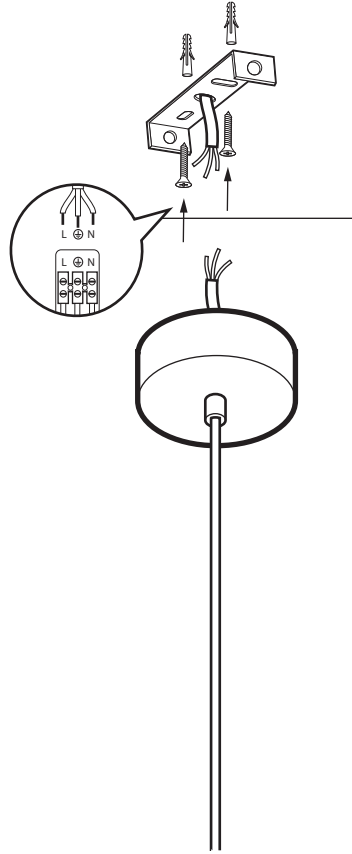

3

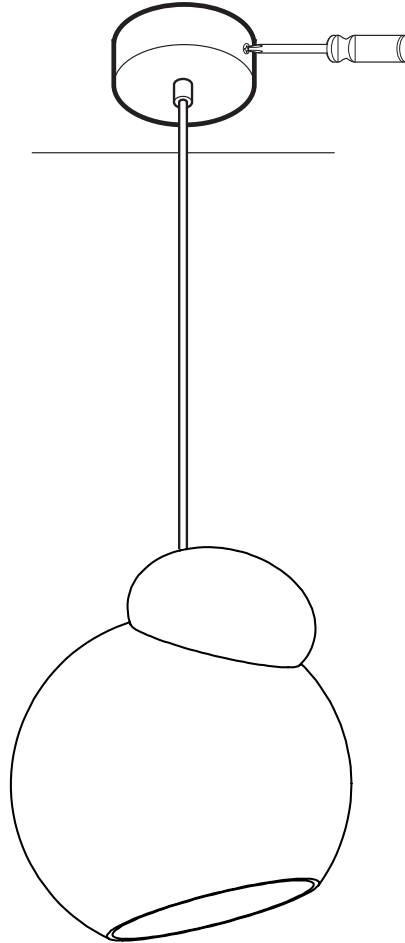

4

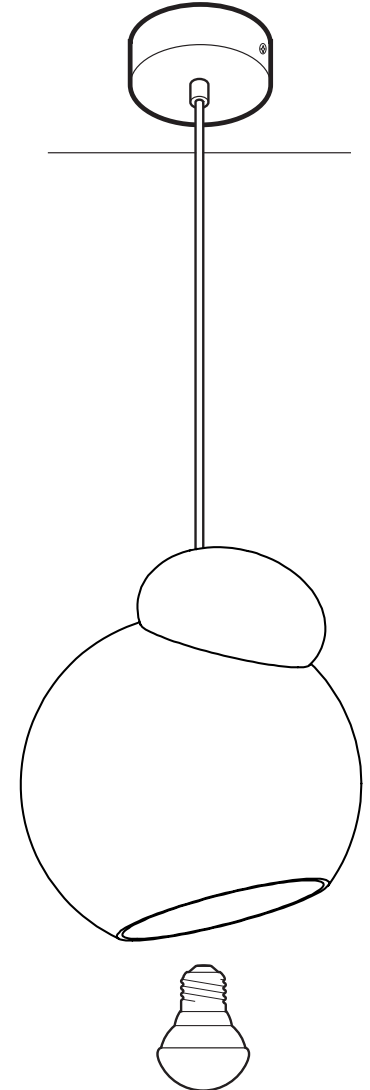

If the external flexible cable or cord of this luminaire is damaged, it shall be exclusively replaced by the manufacturer or his service agent or a similar qualified person in order to avoid a hazard.

AIR

DESIGN BY
FRANSEN DESIGN STUDIO

Ø34cm

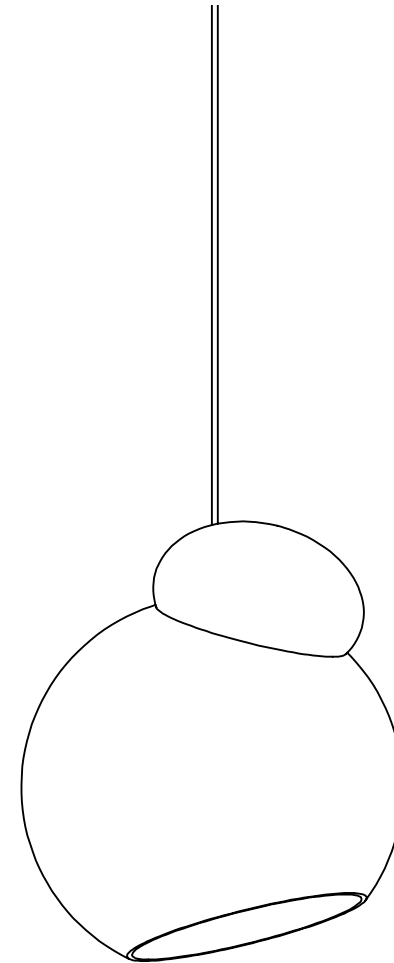

Frandsen has been designing,
producing and marketing lamps
since 1968

*"It is important for us to design
lamps in beautiful materials, and
to make sure that our products
are signalling quality and taste"*

FRANSEN

WWW.FRANSEN.COM

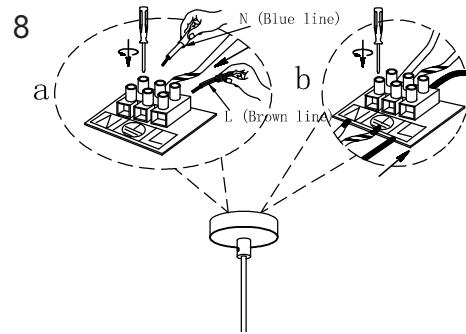
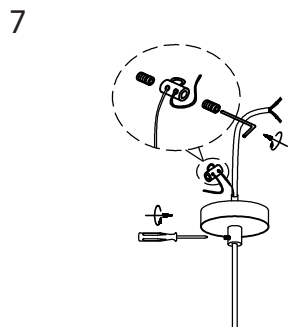
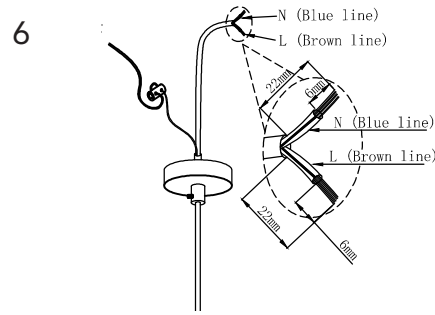
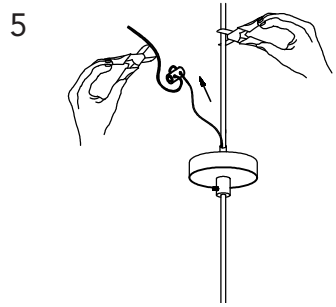
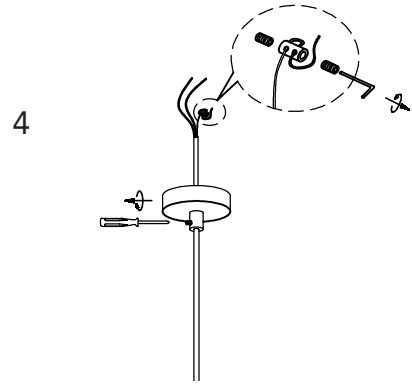
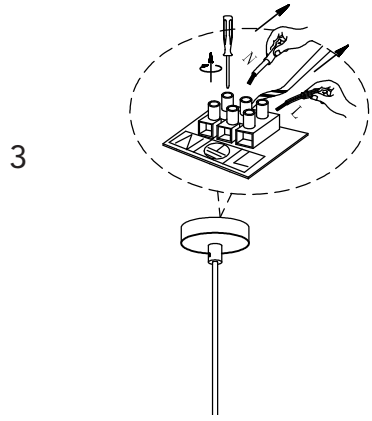

To shorten the wire and the cable follow steps 3 to 8.
To mount the lamp without shortening wire and cable go to step 8b.

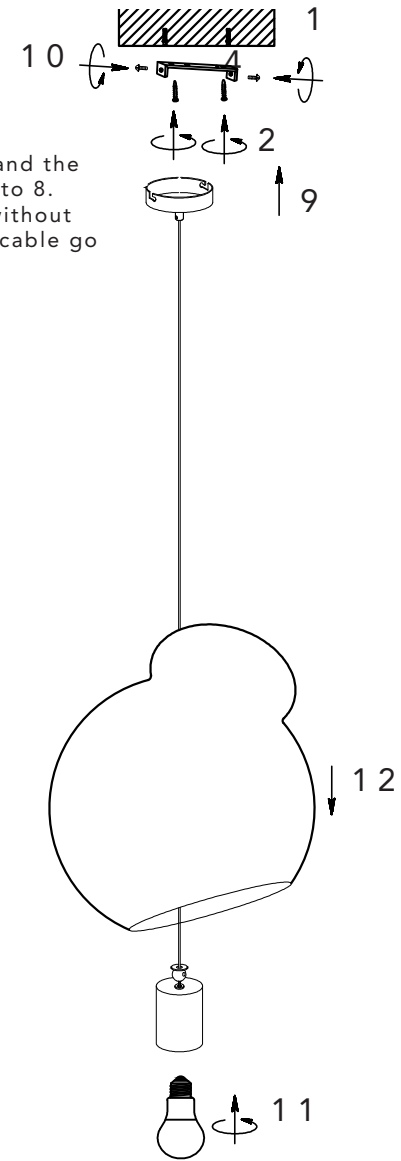

If the external flexible cable or cord of this luminaire is damaged, it shall be exclusively replaced by the manufacturer or his service agent or a similar qualified person in order to avoid a hazard.